

HARDENED WASHERS | ASTM F436

Bolt Size	A		B		C		Weight in Pounds
	Outside Diameter	Inside Diameter	Thickness		Per 1000 Pieces	Per 1000 Pieces	
			Min	Max			
1/2	1-1/16	17/32	0.097	0.177	18		
5/8	1-5/16	11/16	0.122	0.177	33		
3/4	1-15/32	13/16	0.122	0.177	41		
7/8	1-3/4	15/16	0.136	0.177	64		
1	2	1-1/16	0.136	0.177	82		
1-1/8	2-1/4	1-3/16	0.136	0.177	105		
1-1/4	2-1/2	1-3/8	0.136	0.177	133		
1-3/8	2-3/4	1-1/2	0.136	0.177	163		

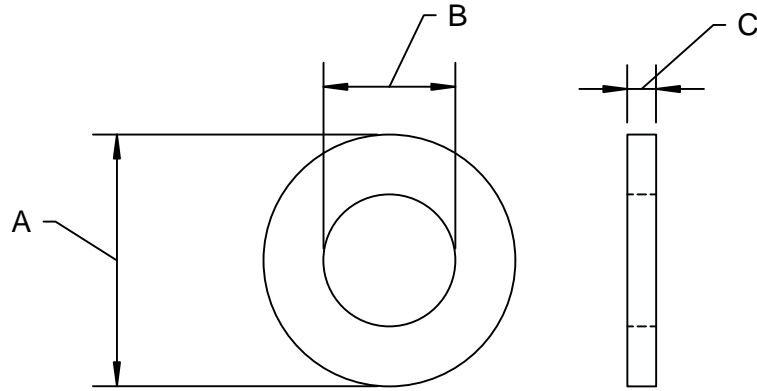

FLAT WASHERS PER ASTM F844

Bolt Size	A		B	C	Weight In Pounds
	Inside Diameter	Outside Diameter	Thickness	Per 1000 Pieces	
3/8	7/16	1	0.083	20	
1/2	9/16	1-3/8	0.109	40	
5/8	11/16	1-3/4	0.134	80	
3/4	13/16	2	0.148	110	
7/8	15/16	2-1/4	0.165	150	
1	1-1/16	2-1/2	0.165	190	
1-1/8	1-1/4	2-3/4	0.165	220	
1-1/4	1-3/8	3	0.165	260	
1-3/8	1-1/2	3-1/4	0.18	330	

GENERAL REQUIREMENTS

- Fasteners are to be produced to specification ASTM F844 or ASTM F436 except where noted on this drawing.
- Shipment Approval / Sample Submission
 - 25-piece sample for each lot must be submitted for approval prior to release of a shipment.
 - Samples must be submitted along with the Certificate of Inspection Report to the following;

TFC QUALITY ASSURANCE CENTER
Pittsburgh, PA

Note: Any company who Triangle Fastener Corporation contracts to produce this "TFC SPECIFIC" product gives up the right to produce, market, or sell this fastener for any other entity. The contracted company fully understands that all design and market information that TFC provides is the property of TFC, and cannot be used without written permission by TFC. COPYRIGHT 2006 TFC

DWG. NUMBER 082212B	REV	DWG. BY JES	APPROVED	REVISIONS			DESCRIPTION FLAT WASHERS	DATE 8.20.12				
CUSTOMER		CUSTOMER APPROVAL		NO.	WAS	DATE	MATERIAL	HEAT TREATMENT	FINISH	CORROSION SPECIFICATION		
		DATE OF APPROVAL					As required by customer					
Design information provided on this drawing is the property of Triangle Fastener Corporation, Pittsburgh, PA. Any use without written permission is prohibited.							PART WEIGHT	NOTES				
							PART NUMBER	PACKAGING	Plain carton with TFC labeling			



TRIANGLE FASTENER CORPORATION

TFC FASTENING SYSTEMS DESIGN CENTER
4661 HINCKLEY INDUSTRIAL PARKWAY
CLEVELAND, OH 44109
PHONE: (216) 351-9933 / FAX: (216) 351-5008
www.trianglefastener.com