

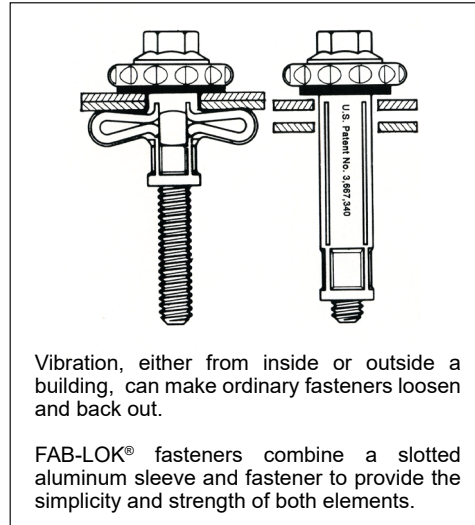

We Stock a Full-Line for Immediate Shipping!

FAB-LOK® fasteners were designed to maintain panel integrity in high-stress environments such as: high wind areas, expansion and contraction, severe vibration, racking and the repair of oversized holes.



Vibration, either from inside or outside a building, can make ordinary fasteners loosen and back out.

FAB-LOK® fasteners combine a slotted aluminum sleeve and fastener to provide the simplicity and strength of both elements.

Sizes

Material	Size	Penetrating Length	Grip Range	Wt. / M
Carbon Steel	FAS 10-4	1.373"	.062"-.250"	23
	FAS 10-8	1.612"	.250"-.500"	24
	FAS10-12	1.807"	.500"-.750"	28
H-3 (300 series) Stainless Steel	FAC10-4	1.373"	.062"-.250"	23
	FAC 10-8	1.612"	.250"-.500"	24
	FAC 10-12	1.807"	.500"-.750"	28

WEATH-R-SEAL Washers	
Part	Description
Aluminum Bonded Weath-R-Seal Washers	.729" O.D. - .040 Aluminum
	1" O.D. - .040" Aluminum
304 Stainless Steel Bonded Weath-R-Seal Washers	.729" O.D. 20 gauge 304 S/S
	1" O.D. 20 gauge 304 S/S

Installation

1. Pre-drill with a 5/16" diameter drill bit
2. Insert FABLOK into hole. Use the FABLOK holding sleeve with a DEWALT screw-gun (DW268 or DW267)

Holding Sleeve
p.n. : EZL900

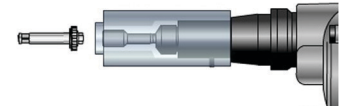

Technical Information

Pull-out tests were performed on a Model L Dillon Dynamometer. FAB-LOK® fasteners were installed in single sheet and two sheets of metal and pulled over the tines of the FAB-LOK® to determine holding values.

Clamping Force

FAB-LOK® Type	FAS
Maximum	900 lbs.
Residual	860 lbs.

Comparison: FAB-LOK® & Sheet Metal SC

Sheet Material	FAB-LOK® FAS-10-4	#14 Sheet Metal Screw
Strip test in .032" Aluminum	75 inch-lbs.*	65 inch-lbs.*
Strip test in 26 ga. Steel	75 inch-lbs.*	45 inch-lbs.*
Strip test in 24 ga. Steel	75 inch-lbs.*	55 inch-lbs.*

Single Shear Strength

FAB-LOK® Type	FAC	FAS
Avg. shear	1885 lbs.	2400 lbs.

Hydrostatic Test

FAB-LOK® Type	H2O Pressure	Length of test	Result
FAC - 10-4	100 psi	5 days	No leaks

Type Fac - Single Sheet

Sheet Material	Sheet Thickness	Failure lbs.*	Type of Failure
Steel	24 ga.	833	Sheet Split
	20 ga.	858	Sheet Split
	18 ga.	1050	Sheet Split
	16 ga.	1293	Sheet Split
	14 ga.	1400	Fastener Broke

Fatigue Tests

Two thicknesses of 26 gauge metal fastened with FAB-LOK® and tested on 5000 lb. capacity machine at 1500 cycles per minute, sustained 1,775,500 cycles when failure of sheets occurred. Fastener did not fail.

FAB-LOK® fastening 1/8" aluminum plate to 3/16" steel of a railroad freight car, held without failure when the car was subjected to jarring vibration by a Hewitt-Robins Car Shaker at 900 cycles for ten minutes.

INFORMATION PROVIDED HERE IS BASED UPON TESTS BELIEVED TO BE RELIABLE. IN AS MUCH AS ELCO FASTENING SYSTEMS HAS NO CONTROL OVER THE EXACT MANNER IN WHICH OTHERS MAY USE THIS INFORMATION, IT DOES NOT GUARANTEE THE RESULTS TO BE OBTAINED NOR DOES THE COMPANY MAKE ANY EXPRESS OR IMPLIED WARRANTY OF MERCHANTABILITY, OR FITNESS FOR A PARTICULAR PURPOSE CONCERNING THE EFFECTS OR RESULTS OF SUCH USE.